

# Autonics

## Door Side Sensor ADS-SE

M A N U A L



Thank you very much for selecting Autonics products.  
For your safety, please read the following before using.

### Caution for your safety

- Please keep these instructions and review them before using this unit.
- Please observe the cautions that follow:
  - Warning** Serious injury may result if instructions are not followed.
  - Caution** Product may be damaged, or injury may result if instructions are not followed.
- The following is an explanation of the symbols used in the operation manual.
  - Warning**: Injury or danger may occur under special conditions.

### Warning

- In case of using this unit with machinery which need safety control(Ex: Nuclear power control, medical equipment, vehicle, train, airplane combustion apparatus, entertainment or safety device etc), it requires installing fail-safe device, or contact us for information on type required. It may cause a fire, human injury or damage to property.
- Do not connect wires in power ON. It may cause an electric shock.
- Do not disassemble or modify this unit. Please contact us if it is required. It may give an electric shock and cause a fire.

### Caution

- This unit shall not be used outdoors. It might shorten the life cycle of the product or give an electric shock. Use this product inside only. Do not use the product outdoors or location subject to temperatures or humidity outside. (Example: rain, dirty, frost, sunlight, condensation, etc.)
- Use it with auto door sensor for safety. It may cause damage of assets or human injury.
- Do not use this unit in place where there is flammable or explosive gas. It may cause a fire or explosion.
- Please observe specification rating. It may shorten the life cycle or damage to the product.
- Do not do wrong wiring. It may cause product damage.
- Do not use this unit where severe shock or vibration exists. It may cause product damage.
- In cleaning the unit, do not use water or an oil-based detergent. It might cause an electric shock or fire that will result in damage to the product.
- Do not use the load beyond rated switching capacity of Relay contact. It may cause insulation failure, contact melt, contact failure, relay broken, fire etc.

### Identification

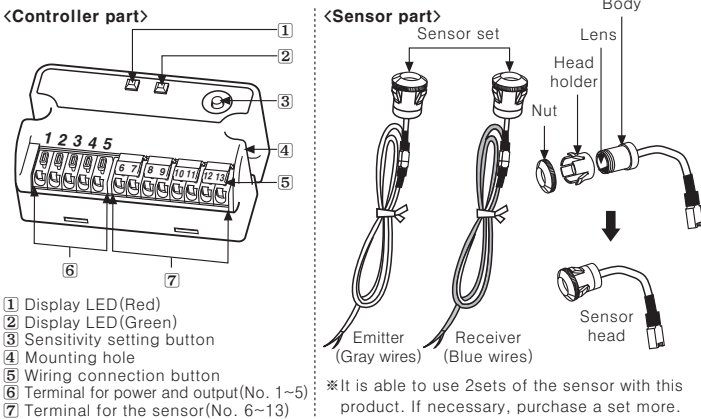

### Installation

#### Controller installation

- Please fix controller with the bolts (M4×20, 2 piece). Please process the fixing hole of controller by M4. Please see dimension for installation.

#### 1. Please follow as below when adjusting wiring length.

- Please cut off the wiring length as much as user needs.
- Please connect the wire to the terminal after taking off the wire covering. It will be easy to connect if soldering the end of the wires.

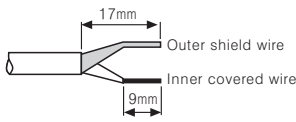

#### 2. Please match wires in the number of terminals and connect them.

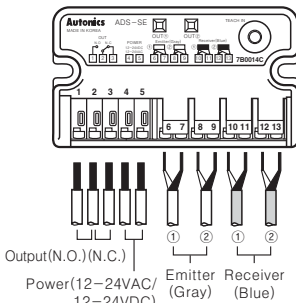

- Connection method for sensor
- Please put outer shield and inner covered wires at once, pressing the inserting button, then take off from the button.

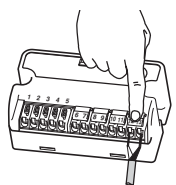

- Connection method for power and output wires.
- Please put the wires pressing the terminal by a driver etc.

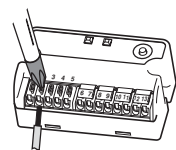

- Allowable diameter of power and output wires.
- Single wire:  $\phi 0.12 \sim 1.6 \text{mm}^2$  (AWG26~16)
- Stranded wire:  $\phi 0.13 \sim 1.5 \text{mm}^2$  (AWG26~16)

### Specifications

ADS-SE	
Model	ADS-SE
Sensor wire length	10m
Detecting type	Through-beam type
Detecting distance	0 ~ 10m
Power supply	12~24VAC/DC $\pm 10\%$ 50/60Hz (Ripple P-P: Max. 10%)
Power consumption/Current	AC: Max. 2VA / DC: Max. 50mA
Contact output	Contact capacity: 50VDC 0.3A (Resistive load) Contact composition: 1C Relay life cycle: Mechanical Min. 5,000,000 times, Electrical Min. 100,000 times
Response time	Approx. 50ms (From a beam cut off)
Output holding time	Approx. 500ms (From a beam received)
Available sensor set	2set
Indication	Operating indicator (See "How to use" for the display status in operation)
Light source	Infrared diode (850nm modulated)
Ambient illumination	Sunlight: Max. 100,000lx (Illumination of received light side)
Ambient temperature	-20 ~ 55°C, Storage: -25 ~ 60°C
Ambient humidity	35 ~ 85%RH, Storage: 35 ~ 85%RH
Protection	IP30 (IEC standards)
Material	Case: ABS, Lens: PMMA
Accessories	Sensor 1set (ADS-SH), Fixed bolt 2 piece
Unit weight	Approx. 300g

\* The temperature or humidity mentioned in Environment indicates a non freezing or condensation environment.

### Dimensions

Controller (ADS-SEC) (Unit:mm)

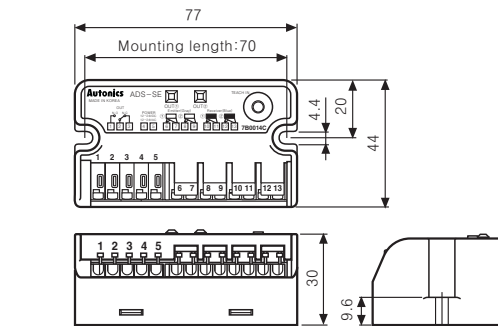

#### Sensor (ADS-SH)

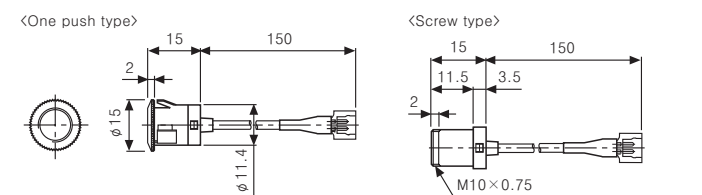

\* It is able to purchase a controller (ADS-SEC) and sensor cable (ADS-SH:10m) separately.

#### Bracket: ADS-SB12, ADS-SB10

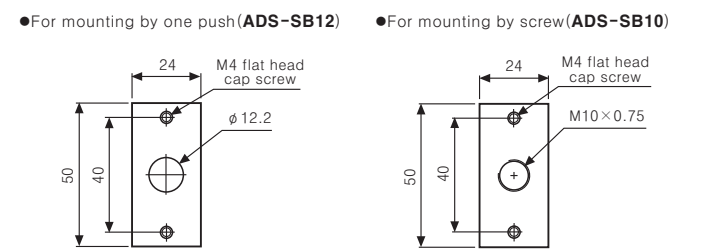

\* The mounting bracket (ADS-SB12, ADS-SB10) of sensor is sold separately.

### Caution for sensor installation

- Detecting distance is 10m. Please install it in rated distance.
- Please install the sensor with more than 50cm gap from the bottom and ceiling. It may cause malfunction by reflected beams from the surface of the bottom and ceiling.
- Please don't put obstacles between emitter and receiver. It may cause malfunction.
- This product is for indoor. Please avoid the place where exposed in direct sunlight or is in over rated intensity of illumination.

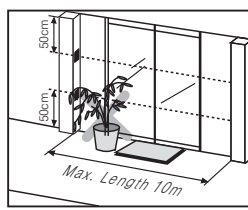

#### 1. Please make a hole on the side post of auto door as follows.

- When not using the mounting bracket
  - Mounting hole of sensor head:  $\phi 12.2^{+0.1} \text{mm}$
  - Panel thickness of sensor head:  $1.5^{+0.5} \text{mm}$
- When using the mounting bracket
  - Through hole of sensor head:  $\phi 13 \sim \phi 14 \text{mm}$
  - Screw hole for fixing the bracket: M4 TAP or  $\phi 3.5$

#### 2. Please mount the sensor head in the mounting hole

- When not using the mounting bracket
  - One push method: Please insert the sensor head into the mounting hole like the right picture.
- When using the mounting bracket
  - One push method
    - Please install the sensor head at the bracket first.
    - Please fix the bracket by screws on the place for installing.

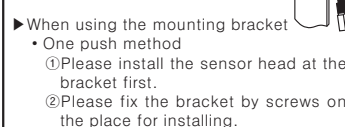

#### 3. Screw method

- Please remove nuts and the head holder from the sensor head.
- Please install the sensor head on the bracket.
- Please fix the bracket on the side post of the door by screws.

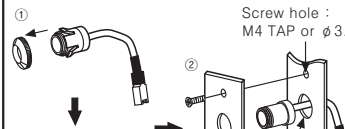
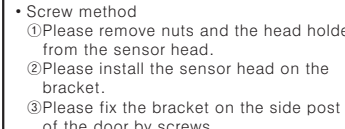

\* The above specifications are subject to change without notice.

### How to use

#### Sensitivity setting

Please set sensitivity after installing this product for a normal operation. Sensitivity setting is what set the optimum sensitivity automatically at the controller according to installed environment.

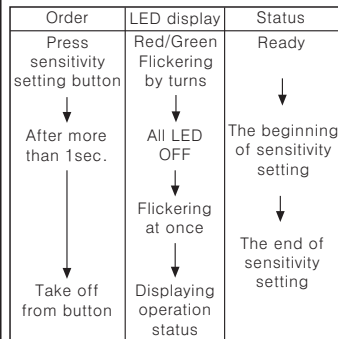

Please check LED display after setting the sensitivity.

- When the pressing time of sensitivity setting button is shorter than 1sec, sensitivity setting is cancelled, then it operates by previous setting.

#### Caution Before sensitivity setting

- Please check the wiring again with the connection diagram.
- When setting sensitivity, the through beam must not be shaken and cut off.
- Please don't put obstacles like a pot on the passage of the through beam.
- It may cause malfunction in above cases from lack of sensitivity or abnormal sensitivity setting.

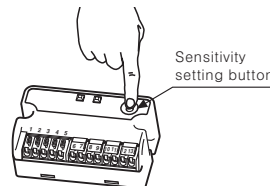

#### Sensitivity status and check after setting sensitivity

Connecting sensor	LED display		Status	
	Red	Green	After setting sensitivity	In operation
1set	LED ON	Flickering	Sensitivity setting success	Beam received
	LED OFF	LED OFF	Sensitivity setting failure	Emitter disconnected or added
	LED OFF	Flickering	---	Lack of sensitivity
2set	LED ON	LED ON	1, 2Channel sensitivity setting success	1, 2Channel beam received
	LED ON	LED OFF	1Channel success, 2Channel failure	Lack of 2channel sensitivity
	LED ON	Flickering	---	1Channel beam received, 2Channel beam cut off
	LED OFF	LED ON	1Channel failures, 2Channel success	1Channel beam cut off, 2Channel beam received
	Flickering	LED ON	---	1 Lack of channel sensitivity
	LED OFF	LED OFF	1, 2Channel sensitivity setting failure	Lack of channel sensitivity or emitter disconnected
	Flickering	Flickering	---	1, 2Channel beam cut off

\* After completing sensitivity setting in using an through beam red LED is flickering, green LED is off. Only red LED displays the operation status.

\* After completing sensitivity setting in using two through beams red LED indicates the operation status of receiver set by receiver ① and green LED indicates the operation status of receiver set by receiver ②.

\* Self diagnostic function  
If lack of sensitivity occurs by optical axes not matched and pollution by dust on the lens of Emitter/Receiver etc. in operation the LED of normal operation channel will be cut off due to unstable operation.

#### Check process for sensitivity setting failure

- Please check obstacles between the heads of Emitter/Receiver.
  - Please check pollutant on the lens of Emitter/Receiver.
  - Please check wires cut off and the connection with the connection diagram on the controller.
  - Please check if the head of Emitter/Receiver is inclined or not.
  - Please set sensitivity again after removing above problem.
- \* When sensitivity setting is failure even though above problem is solved please contact us.

### Operation check

Please check the operation flow chart below.

Operation	LED display	LED OFF	LED ON (Red/Green)	LED OFF	LED ON (Red/Green)
Status	Power OFF	Normal operation	No human or any material between sensors	Human or material is passing between sensors (When through beam cut off)	After human or material passed
Relay output	N.O.	OPEN	OPEN	CLOSE	OPEN
	N.C.	CLOSE	CLOSE	OPEN	CLOSE

### Inspection/Solution for malfunction

Malfunction	Caution	Solution
It is not work.	<ul style="list-style-type: none"> <li>Power voltage</li> <li>Cable cut, disconnection</li> <li>Rated detecting distance</li> </ul>	<ul style="list-style-type: none"> <li>Check the power cable and adjust power voltage.</li> <li>Please check wiring and terminal.</li> <li>Use it in rated detecting distance.</li> </ul>
Sometimes it is not work.	<ul style="list-style-type: none"> <li>Pollution by pollutant on the lens of Emitter/Receiver.</li> </ul>	<ul style="list-style-type: none"> <li>Remove the pollutant.</li> </ul>
It is operated even if people does not enter in detection area.	<ul style="list-style-type: none"> <li>Rated detecting distance</li> <li>There are obstacles between Emitter and Receiver.</li> <li>There are equipments generating strong noise or ratio wave (Motor, Generator, High-tension wire).</li> </ul>	<ul style="list-style-type: none"> <li>Use it in rated detecting distance.</li> <li>Remove obstacles.</li> <li>Keep away from the equipment generating strong noise or ratio wave.</li> </ul>

### Caution for using

- When using two sets of sensor closely it may cause mutual interference by the emitter of other sensor. Therefore, please install them to avoid the interference by exchanging the head of Emitter and Receiver and by keeping the distance between the heads in more than 50cm.
- When installing the sensor head on the ceiling or floor closely it may cause malfunction by receiving the reflected beam. Therefore, please install it by keeping the suitable height (more than 50cm) from the ceiling or floor.
- When the target is a translucent or small object ( $\phi 15 \text{mm}$  max.) it may not detect as the light transmits them.
- When pressing the wiring of sensor in the same pipe laying with the high-tension wire or power line it may cause malfunction. Therefore, please use separated wiring or pipe laying.
- What using it in much dusty or corroded place may cause malfunction. Please avoid these places when installing.
- When making the length of the wiring (power wire or output wire) long it may cause malfunction by surge etc.
- When the lens of sensor head is polluted by dust etc. please clean it by dried cloth slightly. Do not use organic solvent like thinner.
- When using switching power supply as the source of supplying power please ground F.G. terminal and install a condenser for removing noise between 0V and F.G. terminal as following drawing.

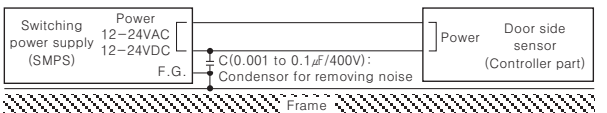

- Installation environment.
  - It shall be used indoor.
  - Altitude Max. 2,000m
  - Pollution Degree 3.
  - Installation Category II

\* It may cause malfunction if above instructions are not followed.

### Major products

- Proximity sensors
- Area sensors
- Door/Door side sensors
- Counters
- Rotary encoders
- Power controllers
- Panel meters
- Temperature controllers
- Tachometer/Pulse(Rate) meters
- Temperature/Humidity transducers
- Switching power supplies
- Stepping motors/drivers/motion controllers
- Field network devices
- Laser marking system (CO<sub>2</sub>, Nd:YAG)
- Laser welding/soldering system
- Photoelectric sensors
- Fiber optic sensors
- Pressure sensors
- Timers
- Display units
- Sensor controllers
- Graphic/Logic panels

**Autonics Corporation**  
http://www.autonics.com

**Satisfiable Partner For Factory Automation**

**HEAD QUARTERS**  
41-5, Yongdang-dong, Yangsan-si, Gyeongsang, 626-847, Korea

**OVERSEAS SALES:**  
Bldg. 402 3rd Fl., Bucheon Techno Park, 193, Yakhde-a-dong, Wonmi-gu, Bucheon-si, Gyeonggi-do, 420-734, Korea  
TEL: 82-32-610-2730 / FAX: 82-32-329-0728  
E-mail: sales@autonics.com

The proposal of a product improvement and development: product@autonics.com