

ARD SERIES

W105 × H52mm Small size, Digital Remote I/O

Features

NEW

- **DeviceNet digital remote I/O**
- Automatic communication speed recognition
: Able to recognize communication speed recognition when connecting with master
- Monitoring of network voltage
: Max. value-Read, Min. value-Read, Setting value-Read/Write, Process value-Read, It enables to receive an abnormality flag of network power by explicit message.
- Single byte I/O : Read/write on single byte
- Multi-byte I/O : Read/write on several bytes
- Reading the number of expansion unit
: Read the number of connected expansion unit
- Reading of unit specification
: Read the specification of standard or expansion unit
- Lengthen the expansion unit
: Able to lengthen expansion model up to 3 units



⚠ Please read "Caution for your safety" in operation manual before using.



Ordering information

AR D - D I 08 A E

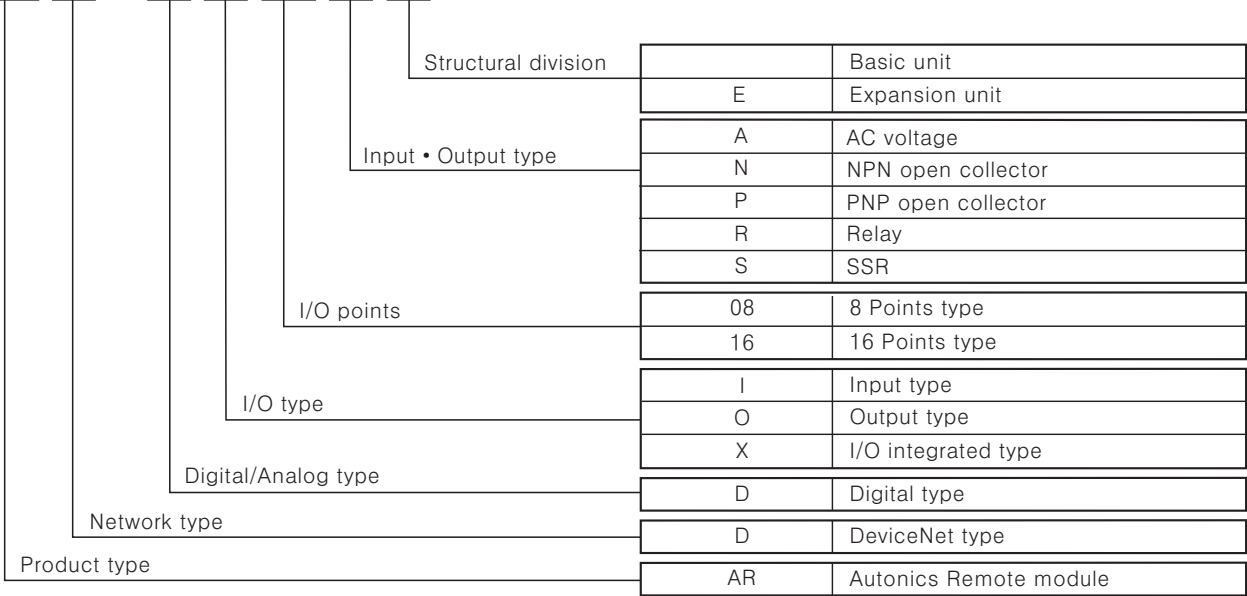

Model

Model		Specification
Basic unit	Expansion unit	
ARD-DI08A	ARD-DI08AE	8 Points of 75-250VAC input(13mA/Point)
ARD-DI16N	ARD-DI16NE	16 Points of 10-28VDC NPN input(10mA/Point)
ARD-DI16P	ARD-DI16PE	16 Points of 10-28VDC PNP input(10mA/Point)
ARD-DO08R	ARD-DO08RE	8 Points of Relay output(2A/Point), Life cycle of contact:100,000 times
ARD-DO08S	ARD-DO08SE	8 Points of SSR output(1A/Point)
ARD-DO16N	ARD-DO16NE	16 Points of NPN output(0.5A/Point)
ARD-DO16P	ARD-DO16PE	16 Points of PNP output(0.5A/Point)
ARD-DX16N	ARD-DX16NE	8 Points of 10-28VDC NPN input(10mA/Point), 8 Points of NPN output(0.5A/Point)
ARD-DX16P	ARD-DX16PE	8 Points of 10-28VDC PNP input(10mA/Point), 8 Points of PNP output(0.5A/Point)

Specifications

Model	ARD-DI08A	ARD-DI16N	ARD-DI16P	ARD-DO08R	ARD-DO08S	ARD-DO16N	ARD-DO16P	ARD-DX16N	ARD-DX16P
	ARD-DI08AE	ARD-DI16NE	ARD-DI16PE	ARD-DO08RE	ARD-DO08SE	ARD-DO16NE	ARD-DO16PE	ARD-DX16NE	ARD-DX16PE
Power supply	Rated voltage : 24VDC, Voltage range : 12~28VDC								
Power consumption	MAX. 3W								
Isolation type	Photocoupler isolated								
I/O points	AC input 8 points	NPN input 16 points	PNP input 16 points	Relay output 8 points	SSR output 8 points	NPN output 16 points	PNP output 16 points	NPN input 8 + output 8 points	PNP input 8 + output 8 points
Control I/O	Voltage	75~250 VAC	10~28VDC		Normal open(NO) 250VAC 2A 1a	30~250 VAC	10~28VDC (Voltage drop : Max. 0.5V)		
	Current	13mA/ Point	10mA/Point			1A/ Point	Output : 0.5A/Point (Leakage current: Max. 0.5mA)	Input : 10mA, Output : 0.5A/Point (Leakage current: Max. 0.5mA)	
Common	8 points, Common			1 point, 1 COM	8 points, Common				
Insulation resistance	Min. 200MΩ (at 500VDC megger)								
Noise strength	±240V the square wave noise(pulse width:1μs) by the noise simulator								
Dielectric strength	1000VAC 50/60Hz for 1 minute								
Vibration	1.5mm amplitude at frequency of 10~55Hz in each of X, Y, Z directions for 2 hours								
Shock	500m/s ² (Approx. 50G) in X, Y, Z directions for 3 times								
Ambient temperature	-10 ~ +50℃ (at non-freezing status), Storage:-25 ~ +75℃								
Ambient humidity	35 ~ 85%RH, Storage:35~85%RH								
Protection	IP20(IEC standard)								
Protection circuit	Surge, Reverse polarity protection circuit (Common) • TR output type Overcurrent protection circuit(NPN type : Operated from 1.9A→ Power is reapplied in overcurrent status, PNP type : Operated at min. 0.7A), Overheating protection4 (165℃ Typical), Short-circuit protection								
Indicator	Network status LED(Green, Red), Module status LED(Green, Red), I/O status LED								
Material	Front case:PC, Body Case:PC, Rubber cap:NBR								
Mounting	DIN rail or screw lock type								
Unit weight	Approx. 150g	Approx. 140g	Approx. 160g	Approx. 170g	Approx. 140g				
Approval	—	CE	—	—	CE				

- (A) Counter
- (B) Timer
- (C) Temp. controller
- (D) Power controller
- (E) Panel meter
- (F) Tacho/ Speed/ Pulse meter
- (G) Display unit
- (H) Sensor controller
- (I) Switching power supply
- (J) Proximity sensor
- (K) Photo electric sensor
- (L) Pressure sensor
- (M) Rotary encoder
- (N) Stepping motor & Driver & Controller
- (O) Graphic panel
- (P) Field network device
- (Q) Production stoppage models & replacement

DeviceNet communication

Item	Specification
Communication	I/O Slave messaging(Group 2 Only slave) • Poll command : Y • Bit_strobe command : Y • Cyclic command : Y • COS command : Y
Communication distance	Max. 500m(125kbps), Max. 250m(250kbps), Max. 100m(500kbps)
Node	Max. 64node(Set by front panel rotary switch)
Communication speed	It is set automatically when connecting with master • 125kbps • 250kbps • 500kbps
Insulation	I/O and inner circuit : Photocoupler is insulated, DeviceNet and inner circuit : Non-insulated, Power of DeviceNet : Non-insulated
Power supply	• Power supply:24VDC • Power range : 12~28VDC • Power consumption:Max. 3W
Approval	ODVA Conformance test

Part description

Basic unit

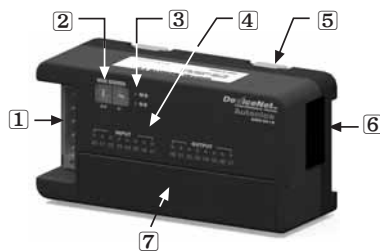

1 DeviceNet Connector

No.	Color	For	Organization
5	Red	24DC(+)	
4	White	CAN_H	
3	None	Shield	
2	Blue	CAN_L	
1	Black	24DC(-)	

2 Rotary switch for address : It is address setting switches displaying the tens digit by 1st one and the units digit by 2nd one.

3 Status LED : It displays the status of unit and network.

4 I/O Status LED : It displays each I/O status.

5 Locking : It is used for holding DIN rail and fixing screw hole.

6 Connector output part : It connects expansion unit.

7 I/O terminal block : It connects I/O with external device.

ARD SERIES

◎ Expansion unit

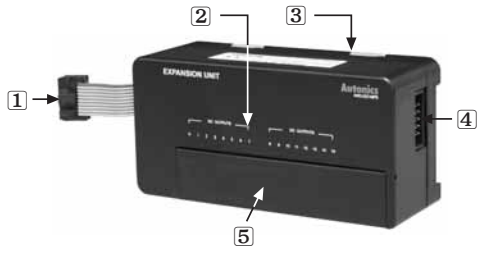

- ① Connector input part : It connects expansion unit and is joined into expansion connector output.
- ② I/O Status LED : It displays each I/O status.
- ③ Locking : It is used for holding DIN rail and fixing screw hole.
- ④ Connector output part : It connects expansion unit.
- ⑤ I/O terminal block : It connects I/O with external device.

■ I/O circuit diagram

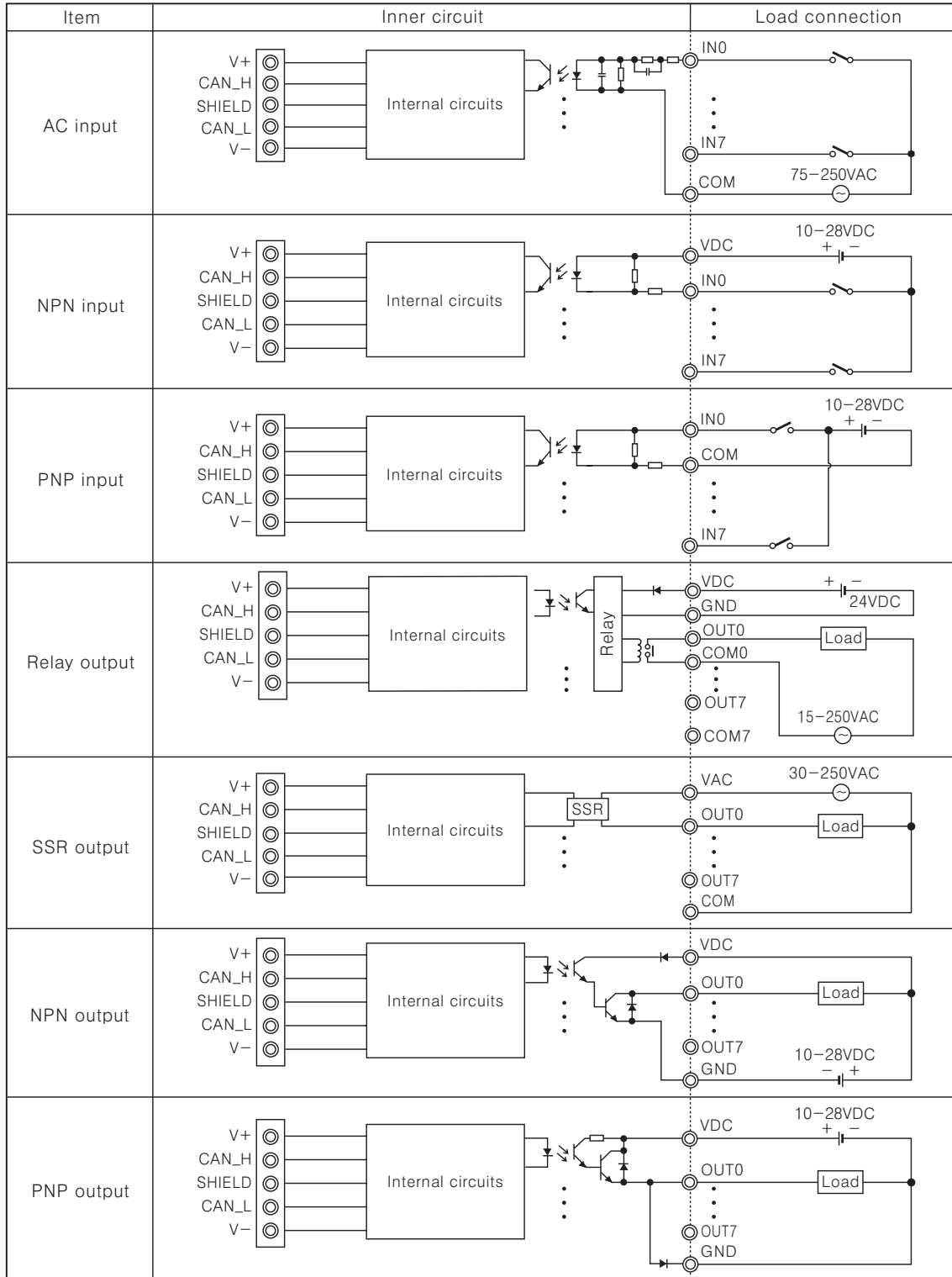

Connections

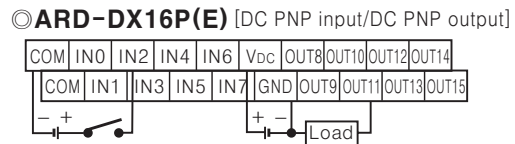
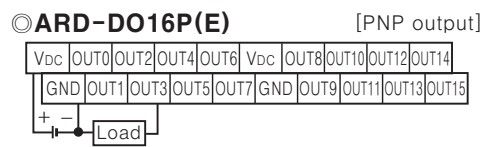
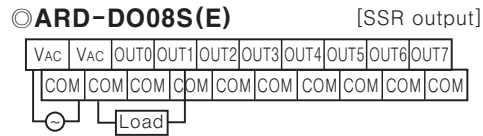
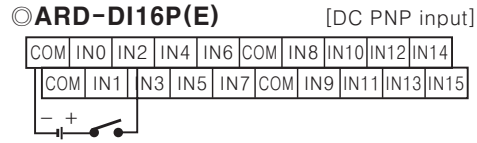
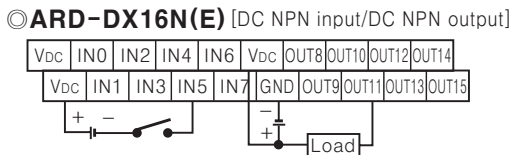
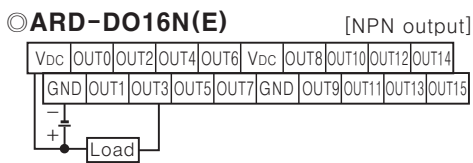
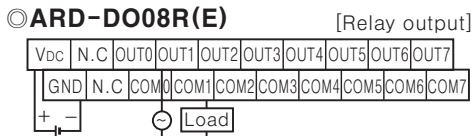
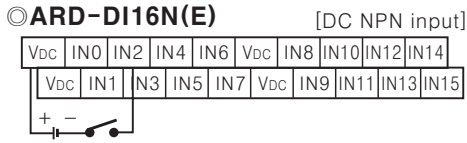
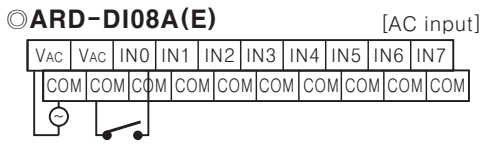

Dimensions

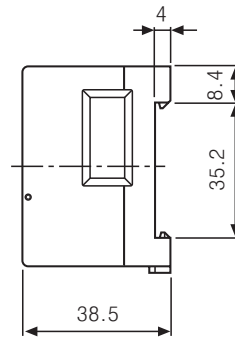
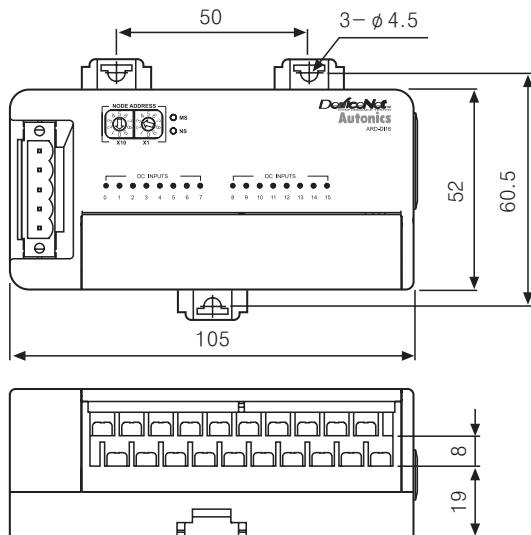

(Unit:mm)

※ It is applied to Basic, Expansion type.
 ※ Connecting connectors are included for expansion units.

Module/Network Status LED

Item	LED	
	LED Status	Description
Module status LED (MS)	Red LED is ON	Unrecoverable error
	Red LED flickers	Recoverable error & Expansion unit communication error
	Green LED is ON	Normal operation
	LED is OFF	Power is not applied
Network status LED (NS)	Green LED flickers	Normal standby
	Green LED is ON	Network On-Line
	Red LED is ON	Dupl MAC ID / Bus-off
	Red LED flickers	Time out
	LED is OFF	Network Off-Line



(A) Counter

(B) Timer

(C) Temp. controller

(D) Power controller

(E) Panel meter

(F) Tacho/Speed/Pulse meter

(G) Display unit

(H) Sensor controller

(I) Switching power supply

(J) Proximity sensor

(K) Photo electric sensor

(L) Pressure sensor

(M) Rotary encoder

(N) Stepping motor & Driver & Controller

(O) Graphic panel

(P) Field network device

(Q) Production stoppage models & replacement

ARD SERIES

■ Installation and setup

○ Setting of address

- Adjust it by rotary switch on front of unit.
- There are two switches, ×10 represents tens digit and ×1 is ones digit and it is able to set 0~63 of address.
- Address will be read when power is supplied to basic units and it is required to restart power to change address.



○ Installation on panel

- ① Pull 3 DIN Rail lockings under the lower part of unit, there is a fixing screw hole.
- ② Place unit on a panel to be mounted.
- ③ Make a hole on a fixing screw position.
- ④ Place screws on 3 holes and tighten them firmly.



○ Installation on DIN rail

- ① Pull 3 DIN Rail lockings on the rear part of unit.
- ② Place unit on DIN Rail to be mounted.
- ③ Fix DIN Rail lockings firmly.



○ Connection of Standard and Expansion unit

- ① Cut off the power supply for a basic unit.
- ② Place the expansion unit to be installed next to the basic unit.
- ③ Connect the cable of expansion unit to expanding connector of basic unit.
- ④ Mount connected expansion units as right figure.
- ⑤ Apply power into basic unit.



■ Communication distance

Baud Rate	Allowable network length	Allowable length of branch line	Allowable expansion length of branch line
125Kbps	500m max.	6m max.	156m max.
250Kbps	250m max.	6m max.	78m max.
500Kbps	100m max.	6m max.	39m max.

■ Terminating resistance

- 120Ω ● 1% of metallic film ● 1/2W

※ Do not install terminal resistance on the unit or, it may cause network problem.
(Impedance can be too high or low.)

If remove node with terminal resistance, it may cause a network problem.

※ Connect terminating resistance on the both ends of the trunk line.

■ Caution for using

1. Make sure that each network unit has its own NODE ADDRESS to prevent NODE ADDRESS duplication error. NODE ADDRESS setting should be done without applying power on the master unit.
2. Make sure to install an expansion unit with a basic unit before supplying power. It may not be able to recognize the expansion unit if installing the expansion unit during the operation.
3. Communication speed of master unit will be automatically set. If changing communication speed of the master unit while operating, make sure to cut off the power of masters and supply again after changing communication speed.
4. Make sure to use standards communication cables, taps and terminating resistance. It may cause communication error if non-standards products are used.
5. Make sure to examine disconnection or short-circuit before connecting cables.
6. Make sure to install terminating resistance on both ends of networks.
7. Avoid installing the units where severe dust exists or where corrosion may occur.