

M4NS/ M4YS

DIN W48×H24mm, W72×H36mm Loop powered digital scaling meter

■ Features

- Loop powered type
- Measurement input : DC4–20mA
- Max. display range : –1999~9999
- Prescale function
- Decimal point change function
- Hi / Low limit input correction function
- Display peak value monitoring function
- Changeable delay time of monitoring peak value
- Display cycle change function
(Selectable 0.5sec./1sec./2sec./3sec./4sec./5sec.)
- Error display function



⚠ Please read "Caution for your safety" in operation manual before using.

■ Ordering information

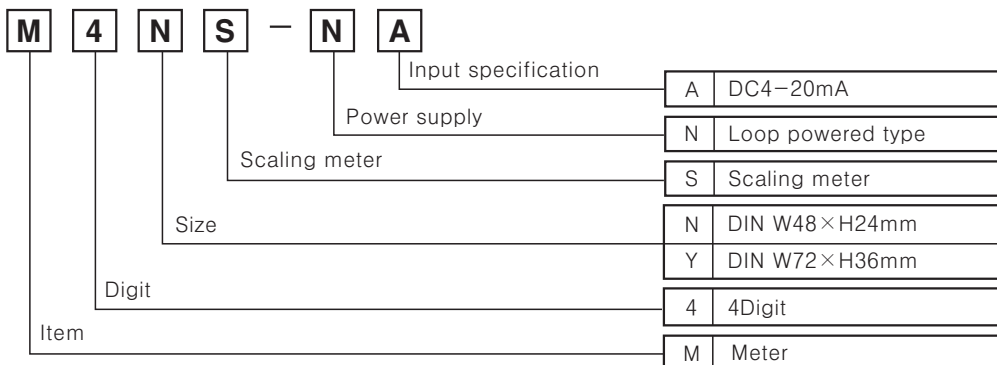

■ Specifications

Model		M4NS-NA	M4YS-NA
Measurement input		DC4–20mA	
Power supply		Loop powered type	
Display method		7 Segment LED Display (4digit)	
Character height		9mm	14.2mm
Display accuracy		(★1) 0.3% full scale of ±1Digit	
Display cycle		Selectable 0.5sec/1sec/2sec/3sec/4sec/5sec	
Resolution		12,000 resolution	
Max. display range		–1999 ~ 9999	
Setting type		Front switches	
Input		(★2) DC4–20mA	
Self–diagnosis function		Error display function (HHHH/LLLL)	
Insulation resistance		Min. 100MΩ (500VDC megger)	
Dielectric strength		2000VAC 50/60Hz for 1minute	
Vibration	Mechanical	0.75mm amplitude at frequency of –10 ~ 55Hz in each of X, Y, Z directions for 1hour	
	Malfunction	0.5mm amplitude at frequency of –10 ~ 55Hz in each of X, Y, Z directions for 10minute	
Shock	Mechanical	300m/s ² (30G) in X, Y, Z directions for 3 times	
	Malfunction	100m/s ² (10G) in X, Y, Z directions for 3 times	
Ambient temperature		–10 ~ 50°C (at non–freezing status)	
Storage temperature		–25 ~ 66°C (at non–freezing status)	
Ambient humidity		35~85%RH	
Unit weight		Approx. 46g	Approx. 88g

※ **(★2)** Ambient temperature (25°C ±5°C): 0.3% full scale of ±1Digit (–10 ~ 50°C: 0.4% full scale of ±1Digit)

※ **(★2)** Impedance between input lines: Max. 600Ω (based on 24VDC)

Please be aware that activating input power is based on 24VDC, and the recommended impedance also will be lowered if the activating power is lower.

Scaling Meter

Front panel identification

●M4NS-NA



●M4YS-NA

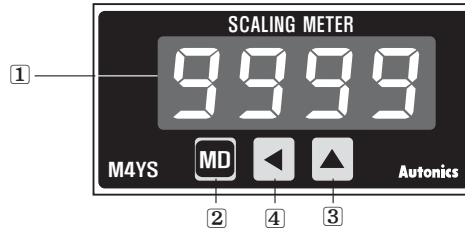

① Display value, Parameter, Error display

② M, MD Key: When enter into Parameter group, return to RUN mode, After completing Parameter setting

③ ▲, ▲ (Up) key: When enter into the status of Parameter setting

④ ◀, ▶ (Shift) key: When enter into the status of Parameter setting and move Digit

Connections

●M4NS-NA

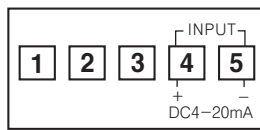

●M4YS-NA

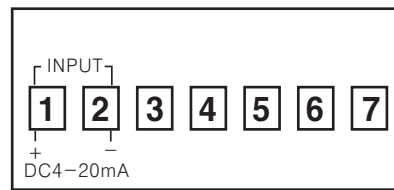

Dimensions

●M4NS-NA

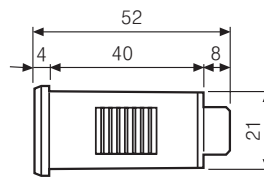
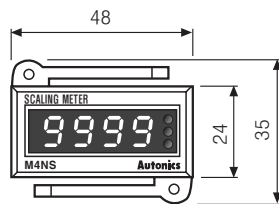
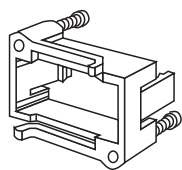

●Panel cut-out

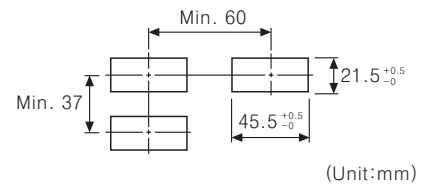

(Unit:mm)

●M4YS-NA

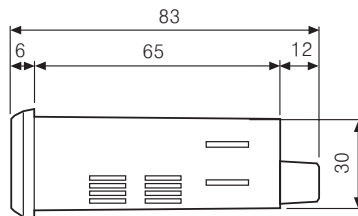
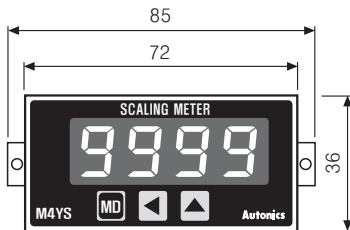

●Panel cut-out

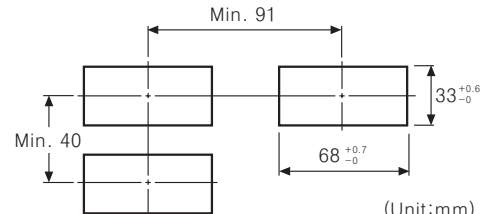

(Unit:mm)

Parameter

Display	Function	Setting range
L-SC	Low scale Low limit display value for 4mA input	-1.999 ~ 9.999 -19.99 ~ 99.99 -199.9 ~ 999.9
H-SC	High scale Hi limit display value for 20mA input	-1999 ~ 9999
dot	Decimal point Set Decimal point position	0000, 000.0 00.00, 0.000
lnb.L	Input bias low Correct the Low-limit value of display value(%)	-100 ~ 100
lnb.H	Input bias high Correct the High-limit value of display value(%)	0.900 ~ 1.100
PEL.t	Peak time See the peak value monitoring delay time	0 ~ 30sec
dis.t	Display period Selectable sampling period(sec)	Selectable 0.5/1.0/2.0/3.0/4.0/5.0sec
E.PCt	Error % Display the measurement input is out of input range	E.PCt 0, E.PCt 1, E.PCt 2, E.PCt 3, E.PCt 4
LoC	Lock Set the lock function	Selectable ON, OFF

Factory default setting

Parameter	Parameter display	Factory default
Low limit display value for 4mA input	L-SC	400
Hi limit display value for 20mA input	H-SC	2000
Set Dot position	dot	0000
Correction of Low limit value input	lnb.L	0000
Correction of Hi limit value input	lnb.H	1.000
Peak value monitoring delay time	PEL.t	015
Display cycle	dis.t	0.5 5
Set % of HHHH/LLLL display range	E.PCt	3
Lock setting	LoC	oFF

(A) Counter

(B) Timer

(C) Temp. controller

(D) Power controller

(E) Panel meter

(F) Tacho/Speed/Pulse meter

(G) Display unit

(H) Sensor controller

(I) Switching power supply

(J) Proximity sensor

(K) Photo electric sensor

(L) Pressure sensor

(M) Rotary encoder

(N) Stepping motor & Driver & Controller

(O) Graphic panel

(P) Field network device

(Q) Production stoppage models & replacement

M4NS/ M4YS

Parameter group 0 (Monitoring mode)

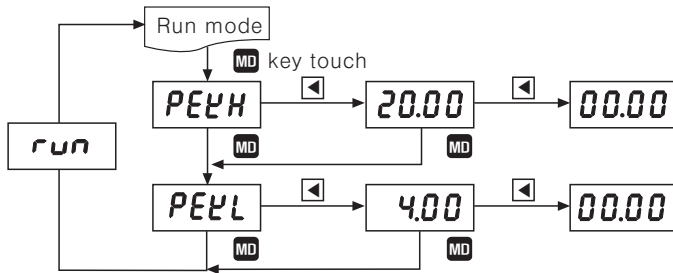

Pressing **MD** key to enter Monitoring mode in RUN mode.

Each Peak value will be shown by pressing **←** key in Monitoring mode and Peak value will be initialized by pressing **←** key once more.

If no key touched for 60sec., it will return to RUN mode.

*When do not use Monitoring function, set **00 5** for **PEEL** in Parameter setting.

Parameter group 1

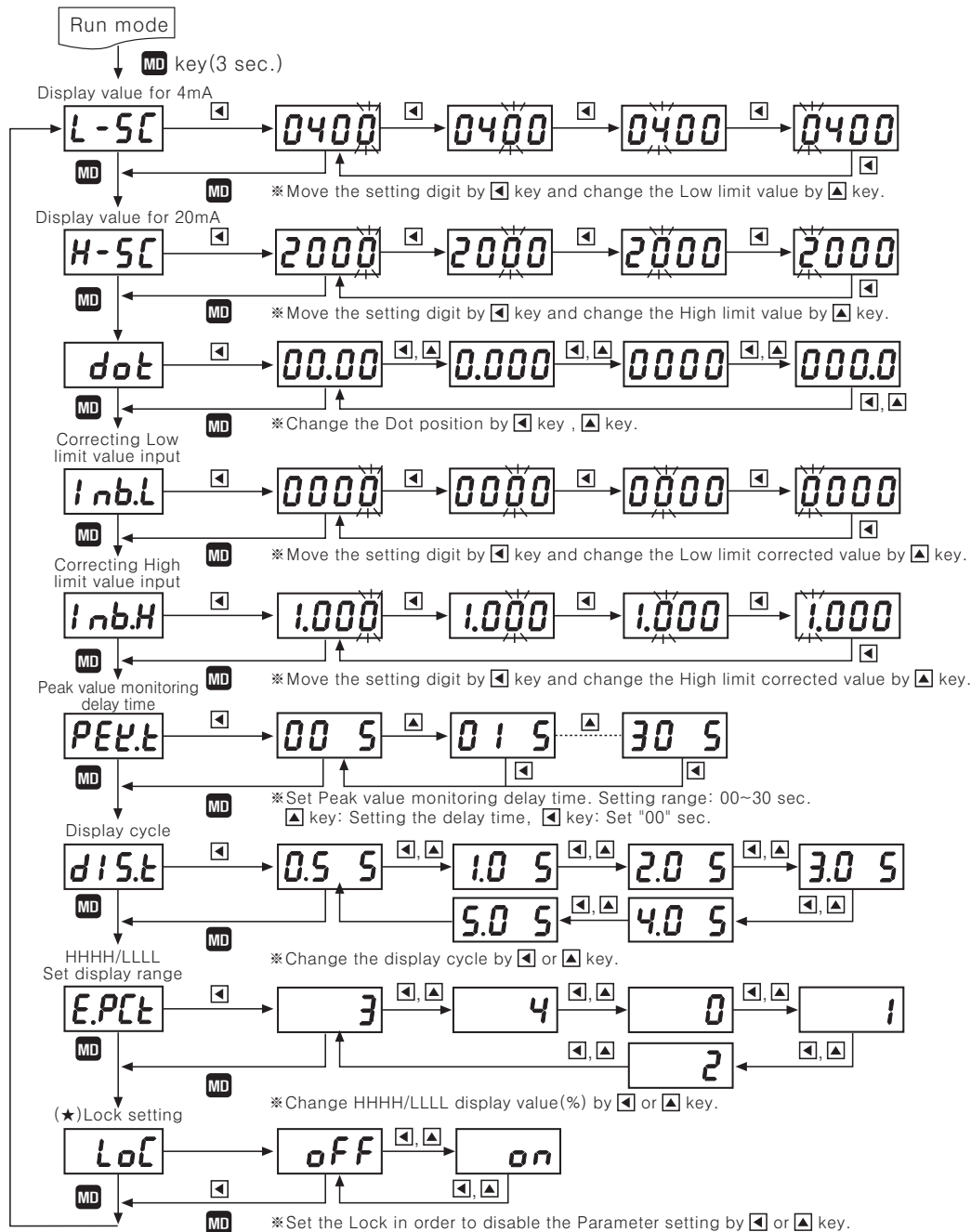

*Press **MD** key to complete the setting and move to next Parameter in status of changing setting value.

*Press **MD** key is pressed for 3 sec. to move to RUN mode after displaying [**run**].

*If any key is untouched for 60 sec., it will return to RUN mode.

* (★) Lock setting **off** : Able to change or set Parameter.

on : Disable to change or set Parameter but enable to check the setting value in Parameter group.
Disable to enter into the status of change setting value by pressing **←**, **→** keys.

Application of connections

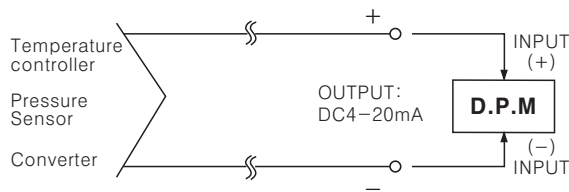

Functions

Prescale function [L-SC / H-SC]

This function is to display the value setting certain Hi/Low limit value against DC4-20mA input. For example if set a=DC4mA, b=DC20mA and A, B as display value, it will be displayed a=A, b=B.

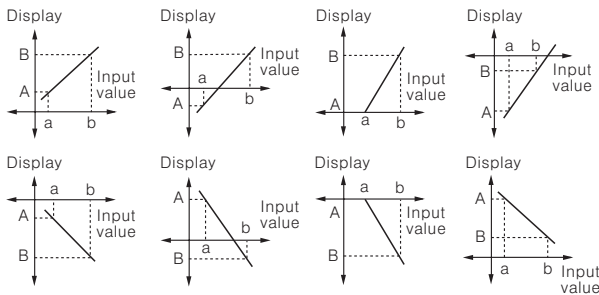

Decimal point setting function [dot Mode]

This function is to set the decimal point position of display value (Set in Parameter setting group)

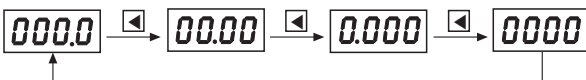

Able to use ◀ (Shift) or ▶ (Up) for moving decimal point.

Correction function [I nb.H / I nb.L]

This function is to adjust the error of display value after calculating scale value for measuring input and also correct the input error of sensor etc.

I nb.L : -100 to 100 [Adjust deviation of low value]

I nb.H : 0.900 to 1.100 [Correct gradient(%) of high value]

Ex) When display value is 0.0 to 500.0 against 4-20mA input,

if the display value is "1.2" for 4mA input, set -12 (Ignore the decimal point) as **I nb.L** value to display "0.0". It is enable to remove offset of Low display value.

※ When completed above Low value setting then apply 20mA, if the display value is "500.5", the correction value will be $5005/5000=0.999$, set 0.999 as **I nb.H** value then enable to correct High value is $50005 \times 0.999 = 5000$. It is also ignore the decimal point.

Display cycle delay function

It is difficult to display when the measuring input value is fluctuating. In this case it is able to make display value stable by delaying display cycle.

Display cycle can be changed in **dis.t** mode of Parameter 2 (Selectable 0.5s/1.0s/2.0s/3.0s/4.0s/5.0s). If select 5.0s, it will be the measuring input value on an average for 5sec., then display it every 5sec.

Error display function [E.P.Ct]

● Error setting and sort

It will display the error message according to the setting value which set % value against analog input range and set it in **E.P.Ct** mode by ◀, ▶ key.

Error code	Error description
E.P.Ct 0	LLLL / HHHH are displayed when it is over 0% out DC4-20mA range
E.P.Ct 1	LLLL / HHHH are displayed when it is over 1% out DC4-20mA range
E.P.Ct 2	LLLL / HHHH are displayed when it is over 2% out DC4-20mA range
E.P.Ct 3	LLLL / HHHH are displayed when it is over 3% out DC4-20mA range
E.P.Ct 4	L-SC / H-SC are displayed always when it is out of DC4-20mA range

● Error display

① When **LLLL** flickers,

Input current is lower than 3% in 4-20mADC (16mA scale)

LLLL will flicker when it is under 3.52mA [16mA × 3% = 0.48mA] → 4mA - 0.48mA = 3.52mA When it is beyond Min. display value (-1999) [by display value]

② When **HHHH** flickers,

Input current is higher than 3% in 4-20mADC (16mA scale)

HHHH flickers [16mA × 3% = 0.48mA] → 20mA + 0.48mA = 20.48mA.

When it is higher than 20.48mA.

When it is beyond Max. display value (9999) [by display value]

● Turn Error display off

LLLL and **HHHH** are displayed when input is out of measuring range, therefore it will be disappeared automatically when input returns to measuring range.

Display peak value monitoring function [PEYH / PEYL]

This function is to monitor Max. value and Min. value by current display value then display its Data in **PEYH** mode and **PEYL** mode.

Enable to set delay time in **PEY.t** mode to protect the wrong Data by initial over current and settable from 0 to 30sec. and start to monitor after delay time.

(A) Counter

(B) Timer

(C) Temp. controller

(D) Power controller

(E) Panel meter

(F) Tacho/ Speed/ Pulse meter

(G) Display unit

(H) Sensor controller

(I) Switching power supply

(J) Proximity sensor

(K) Photo electric sensor

(L) Pressure sensor

(M) Rotary encoder

(N) Stepping motor & Driver & Controller

(O) Graphic panel

(P) Field network device

(Q) Production stoppage models & replacement